

Machine Rating

Rated operating capacity	343 kg
Tipping load	686 kg
Pump capacity	37 l/min @ 100% efficiency
System relief at quick couplers	207 bar
Max. travel speed	9.8 km/h

Engine

Make / Model	Kubota / D1005-E3B-BC-3
Fuel / Cooling	Diesel / Liquid
Max power @ 3000 RPM (SAE J1349)	16.8 kW
Torque at 2200 RPM (SAE J1349)	62.8 Nm
Number of cylinders	3
Displacement	1001 cm ³
Fuel tank capacity	24.6 l

Weights

Operating weight	1268 kg
------------------	---------

Controls

Vehicle steering	Direction and speed controlled by two hand levers
Loader hydraulics tilt and lift	Separate foot pedals
Front auxiliary	Lateral movement of right-hand steering lever

Drive System

Transmission	Infinitely variable tandem hydrostatic piston pumps, driving two fully reversing hydrostatic motors
--------------	---

Standard Features

Automatically activated glow plugs	Rear and top window
Bob-Tach™ frame	Seat belt
Bobcat Interlock Control System (BICS)	Seat bar
Engine / Hydraulic system shutdown	Spark arrester muffler
Front auxiliary hydraulics	CE certification
High-back cushion suspension seat	
Instrumentation	
Lift arm support	
23 x 5.70-12, 4-ply, Narrow tyres	
Operating lights, front and rear	
Operator cab	
Parking brake	

* Roll Over Protective Structure (ROPS) – meets requirements of SAE-J1040 and ISO 3471

Options

Heated enclosed cab	23 x 8.50-12, 6-ply, Heavy duty tyres
---------------------	---------------------------------------

Dimensions

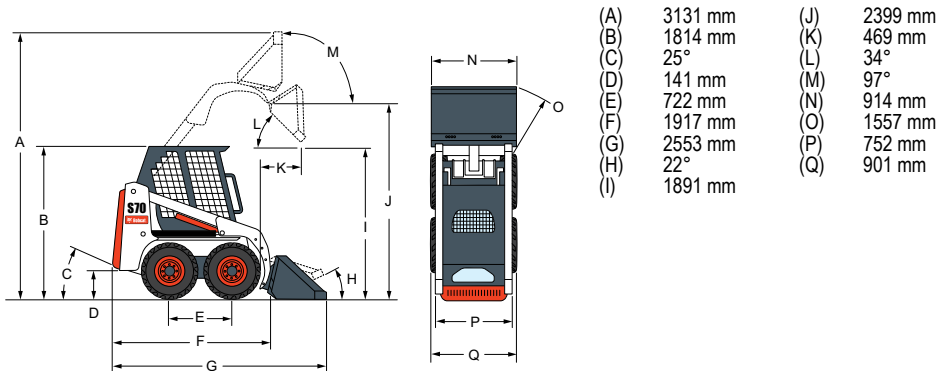

Attachments

- Angle broom*†
- Auger
- Backhoe
- Buckets
- Digger
- Dumping hopper
- Farm grapple
- Hydraulic breaker**
- Landplane
- Mini scraper
- Pallet fork
- Snow blower*
- Snow V-blade
- Soil conditioner
- Stump grinder
- Sweeper
- Tiller
- Trencher
- Utility blade
- Utility forks
- Utility grapple

*Attachment control kit required.

**When operating the loader with this attachment, a Special Applications Kit, which includes a 12 mm Lexan front door with 6 mm top and rear windows, must be used.

†Optional water kit.



www.bobcat.eu